

**GRAIN
NOZZLE**

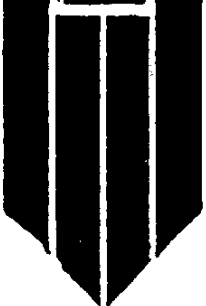

**TECHNICAL MANUAL
FOR
REDWING DUST CONTROL NOZZLE
Models K-870 and K-870-M**

MANUFACTURED BY



**REDWING
TECHNICAL
SYSTEMS, INC.**

8501 Macon Road
Cordova, TN 38018
(901) 753-DUST
(3878)

**THE REDWING NOZZLE PROCESS and THE NOZZLE
in all its various forms are patented under U.S.
Patents No. 4203535, 4342383, and 6085987.**

TECHNICAL MANUAL
FOR
REDWING DUST CONTROL NOZZLE
Models K-870 and K-870-M

The REDWING NOZZLE represents the latest technology in the control of dust emissions at points where dust-laden materials are being loaded . . . controlling the dust within the particulate stream rather than removing it.

Every reasonable effort has been made to produce this product in such a manner as to be as serviceable, wear-resistant and maintenance free as possible.

However, like any piece of equipment, the nozzle requires proper installation and maintenance to adequately perform its function. This manual is to guide you in the installation and maintenance.

If you experience any difficulty in proper function, please contact your dealer.

WARRANTY

THE REDWING NOZZLE IS WARRANTED TO BE FREE FROM DEFECTS IN MATERIALS AND WORKMANSHIP FOR A PERIOD OF ONE YEAR FROM THE DATE OF PURCHASE PROVIDED THAT THE NOZZLE IS INSTALLED AND USED STRICTLY IN ACCORDANCE WITH THE INSTRUCTIONS PROVIDED BY THE MANUFACTURER. REDWING WILL REPAIR OR REPLACE, AT ITS OPTION, ANY NOZZLE OR PART THEREOF FOUND TO BE DEFECTIVE DURING THE WARRANTY.

THIS WARRANTY IS IN LIEU OF ALL OTHER WARRANTIES, EXPRESS OR IMPLIED. THE MANUFACTURER MAKES NO WARRANTIES OF MERCHANTABILITY, SUITABILITY OR FITNESS FOR A PARTICULAR PURPOSE AND ASSUMES NO LIABILITY FOR INCIDENTAL OR CONSEQUENTIAL DAMAGES, INCLUDING, BUT NOT LIMITED TO, LOSS OF INCOME OR PROFITS.

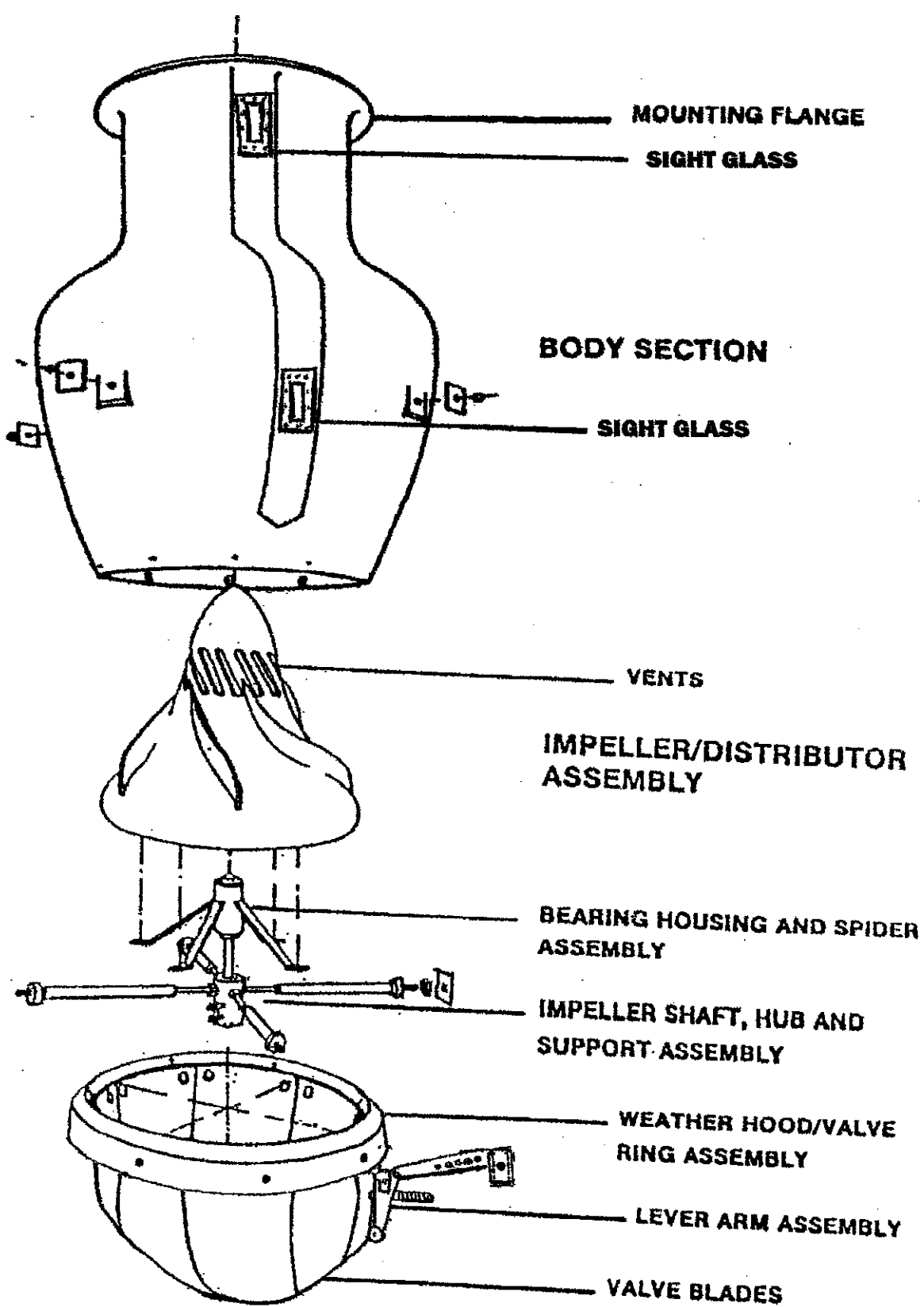

REDWING NOZZLE
SYSTEM COMPONENTS
MODEL K-870

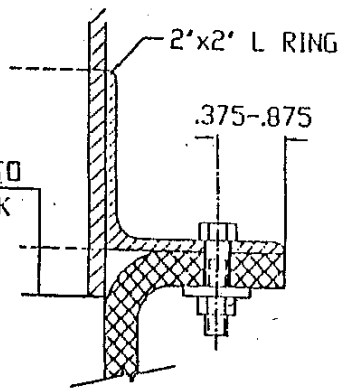
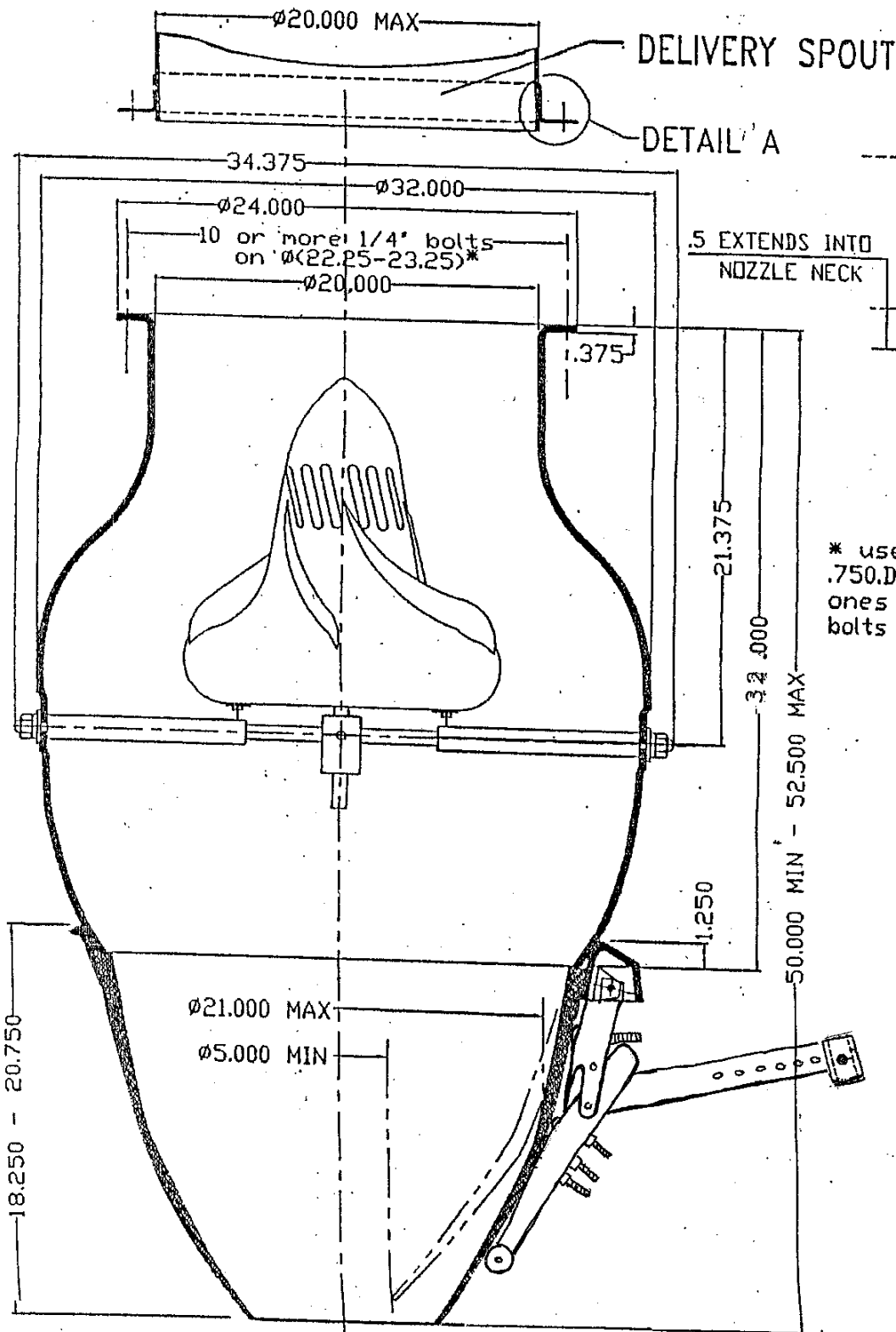

DETAIL A

* use round washers .750.D or rectangular ones 2.0x.75x.1 between bolts and plastic parts.

REDWING NOZZLE

Model K-870

CHART I

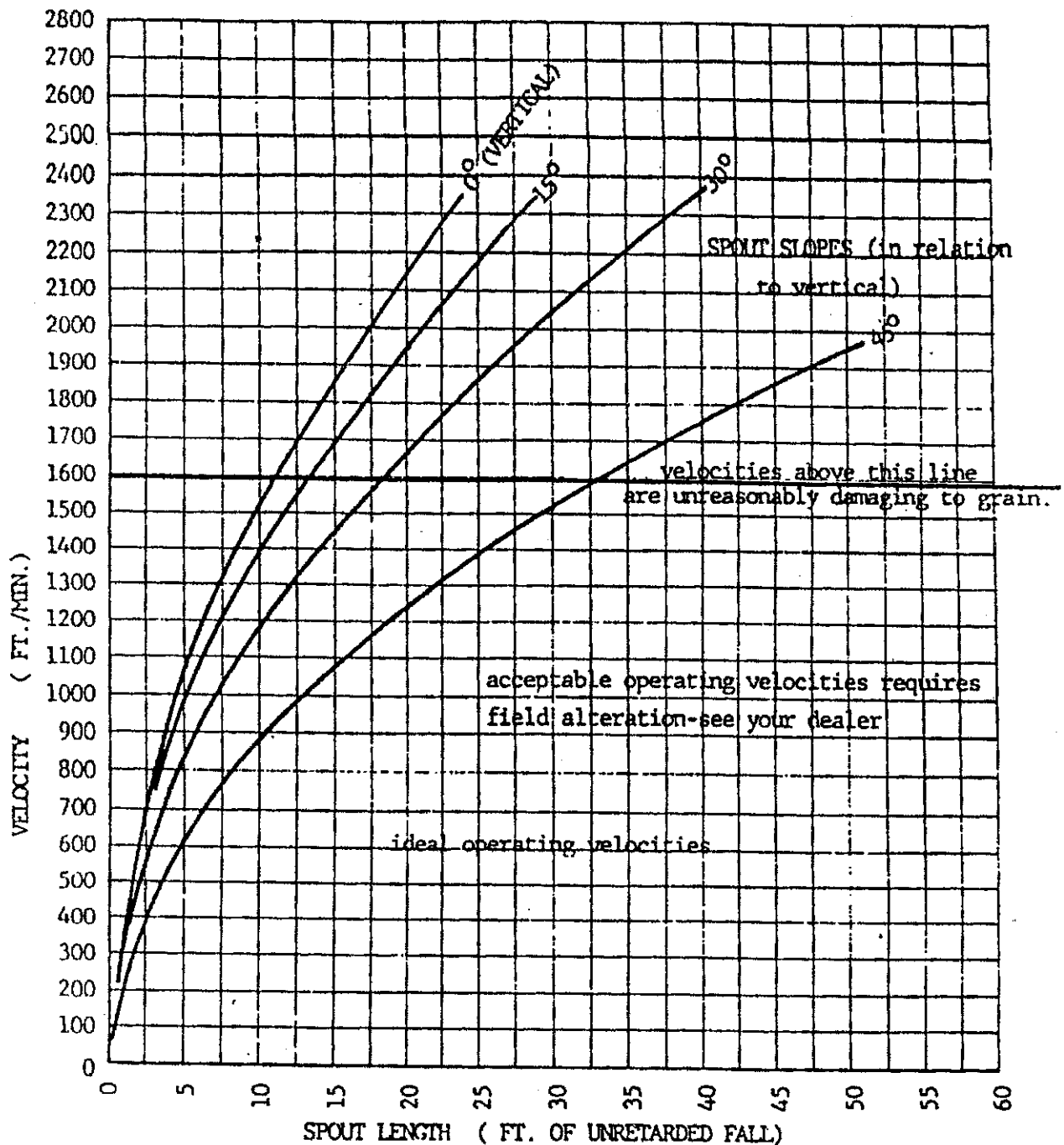

FLOW RATE CHART

To protect whole grains against excess breakage velocities should not be allowed to exceed about 1600 ft./min. (This is true for all grain operations and is not because of the Redwing Nozzle. Other products may require even lower velocities.)

This chart is indicative of the grain velocities that may be expected in proportion to spout angle and slope. The various weights and flow characteristics of different grains and meals can also effect the through-put volume. Best action of the nozzle and less grain breakage will result from actions being taken to keep velocities below 1600 ft./min. Your dealer can advise.

INSTALLATION

1. Volume Capacity

As different materials have different speed-of-flow characteristics, businesses which run several different materials from time to time may require adjustments of the FLOW CONTROL VALVE for the material being loaded at that time.

2. Transition (not furnished)

Supply Pipe to NOZZLE Neck: See Schedule A (pg. 4):

The relationship between flow rate and minimum pipe size is important as air is evacuated back into the supply pipe.

See NOZZLE mounting Flange detail, pg. 4

VALVE CONTROL MECHANISM

The flow rate through the valve is controlled by a system of adjustable lever arms. Variations in the position and pressure of these arms allow almost infinite variations of flow rate adjustment within limits of the nozzle's capacity.

The urethane blades of the flow control valve work in a double action . . . the blades flexing first at the top, between the ring to which they are attached and the bend in the blade; secondary action is between the bend and blade tip.

The upper arm of the blade control mechanism is adjustable and its position is important as a stop point limiting the deflection of the upper part of the blade.

MAINTENANCE/TROUBLE SHOOTING

DO:

- Check unit for any clogging or freezing of valve blades prior to running unit in freezing weather.
- Before any day's run check valve blades to verify that nothing is between the blades. This could detrimentally affect the blade-to-blade dust seal.
- Check for foreign objects jamming impeller or impeding flow.

DO NOT:

- Attempt to run wet grain (moisture content above 30%) through nozzle. Wet grain dust is very cohesive and adhesive and can clog gap between distributor and body of nozzle.
- If it becomes absolutely necessary to run wet grain through the nozzle; be sure to have an observer on hand to monitor the flow and clean unit out immediately after wet grain run is complete.
- Never use welding equipment above nozzle!

NOTE:

Since it is possible to choke the material flow through the nozzle with large foreign objects, it is recommended that a micro-switch cut-off be installed in the supply pipe just above the unit to cut off supply in such an event. ASK YOUR DEALER.



REDWING TECHNICAL SYSTEMS, INC.

8501 Macon Road
Cordova, TN 38018-6101
(901) 753-DUST (3878)
FAX (901) 753-3878
E-mail: dust@redwingtechnical.com
www.redwingtechnical.com

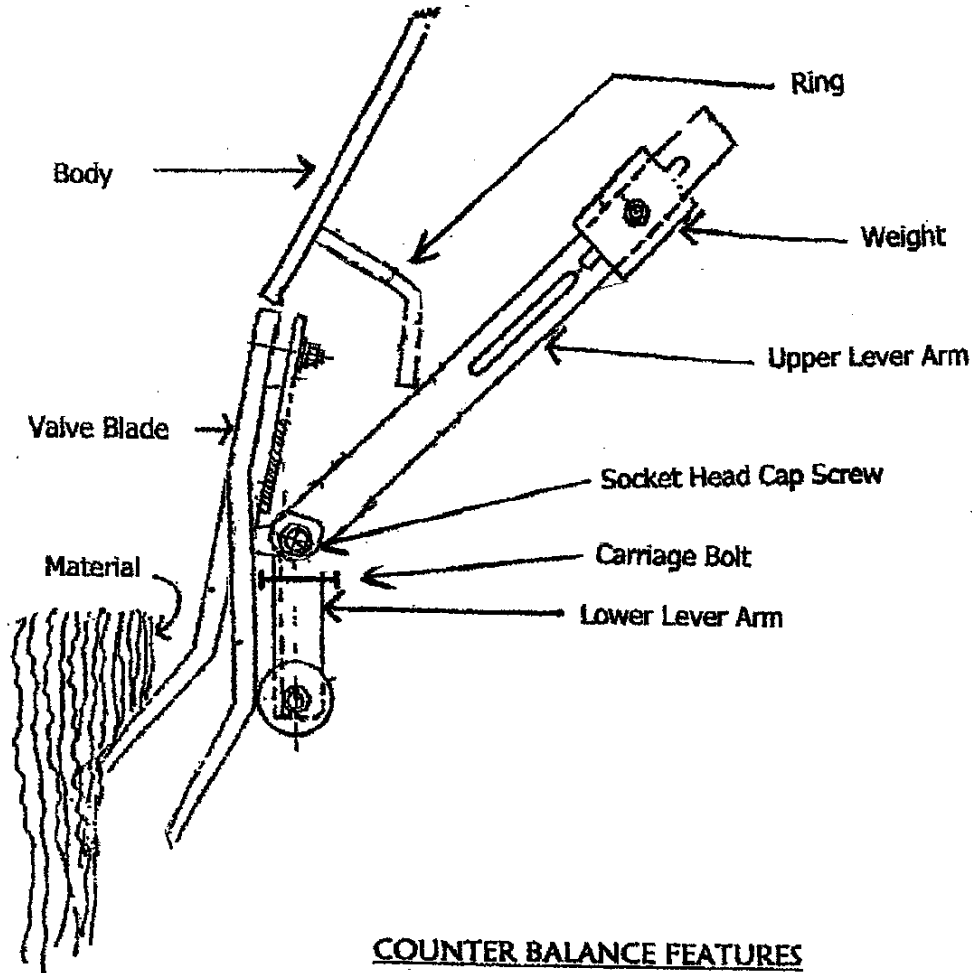

COUNTER BALANCE FEATURES

As the material flow builds up on the valve blades, this creates "weight" that raises up the lever arm with the counter balance attached and opens the valve blades.

There are three adjustment factors in using the counter balance:

- 1) The size of the weights
- 2) The position of the weights on the lever arm - in or out
- 3) The inward length of the carriage bolt

The key in using the counter balance is to find the mixture of these three adjustments to always keep valve pressure on the material flow, but not too much pressure to cause the material to backup.



REDWING TECHNICAL SYSTEMS, INC.

8501 Macon Road
Cordova, TN 38018-6101
(901) 753-DUST (3878)
FAX (901) 753-3878
E-mail: dust@redwingtechnical.com
www.redwingtechnical.com

INSTRUCTIONS FOR COUNTER BALANCE MODEL

Material accumulates in the nozzle. This accumulation of material creates weight on the valve blades. As the weight increases, the lever arms are raised allowing the material to exit the nozzle. The material flow always has valve blade pressure applied by the counter balance.

There are three adjustment factors in using the counter balance:

1. The size of the weights
2. The position of the weights on the upper lever arm - in or out
3. The inward length of the carriage bolt

The key in using the counter balance model is to find the mixture of these three adjustments to always keep valve blade pressure on the material flow, but not too much pressure to cause the material to backup.

A. Position of Upper Lever Arms

- 1) Place upper lever arms at 9 o'clock or 3 o'clock (horizontal) position and install socket head cap screw where upper lever meets the lower lever arms.
- 2) Tighten the 3/8" bolt.

B. Selection of Weight Sizes

During testing, we have found it advisable to attach a wire (12 gauge) to the weights to allow hanging on the upper lever arms. Once the desired weights have been selected, use bolts to attach the weights.

- 1) Attach the weights in the outer hole on the upper lever arm.
- 2) Start with weights that cause the lower level arm to push the valve blades into a closed position.

C. Start loading material

Begin the material flow and add or delete weights to obtain the required counter balance pressure on the material flow.

Fine tuning of the counter balance can be obtained by moving the weights in or out in the holes on the upper lever arm.

D. Inward Length of Carriage Bolt(s)

If there is "dust" escaping between the valve blades, extend the length of the carriage bolt(s) inward to put more pressure on the middle of the valve blades.

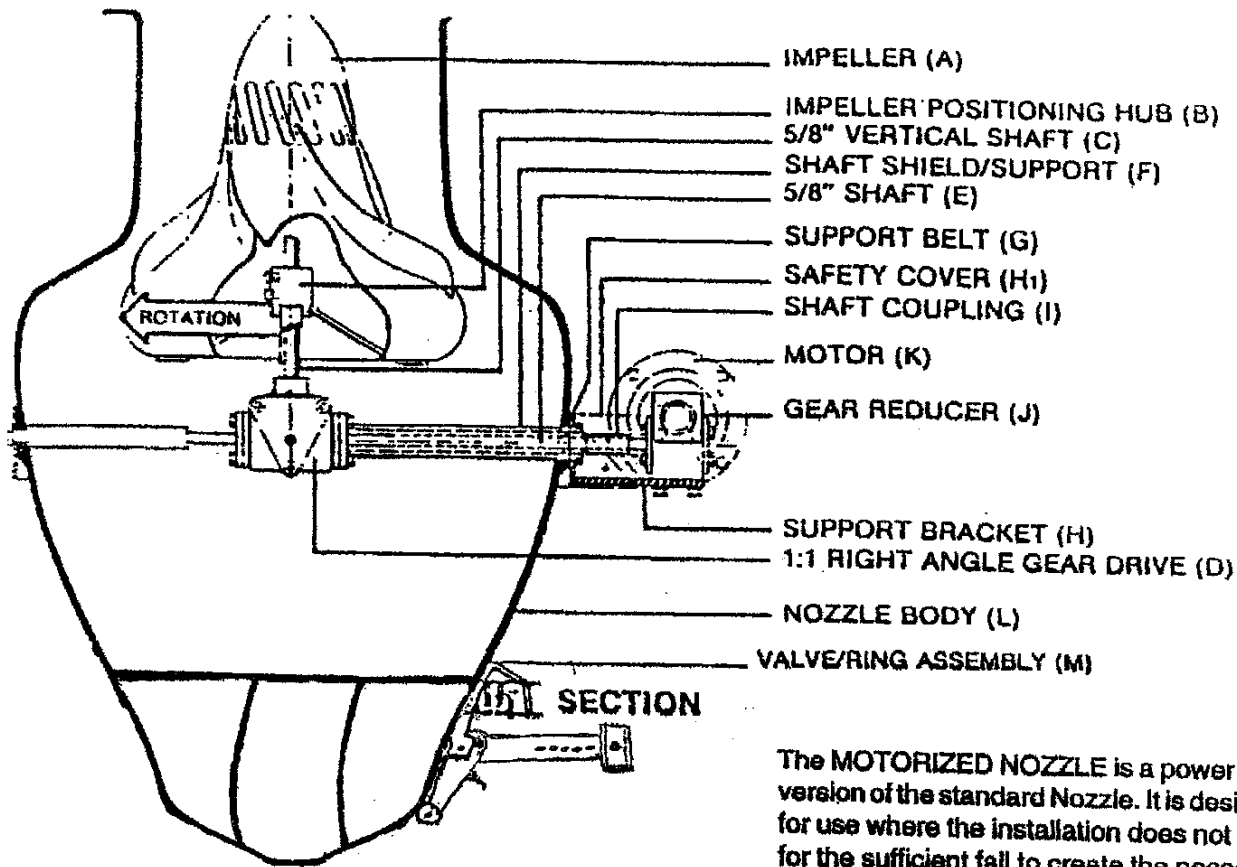

The **MOTORIZED NOZZLE** is a power drive version of the standard Nozzle. It is designed for use where the installation does not allow for the sufficient fall to create the necessary force to drive a free impeller.

(K) MOTOR: 1/3 HP EXPLOSION PROOF

(J) 30:1 Right angle gear reducer. Motor and gear reducer are shipped separately and are mounted to the Nozzle at the job with the hardware supplied.

Both gear drives are lubricated at the factory. However they should receive periodic lubrication maintenance.

Access to the internal gear drive and the impeller gap adjustment set screws is attained by removal of the entire valve/ring assembly (M) from the nozzle body.

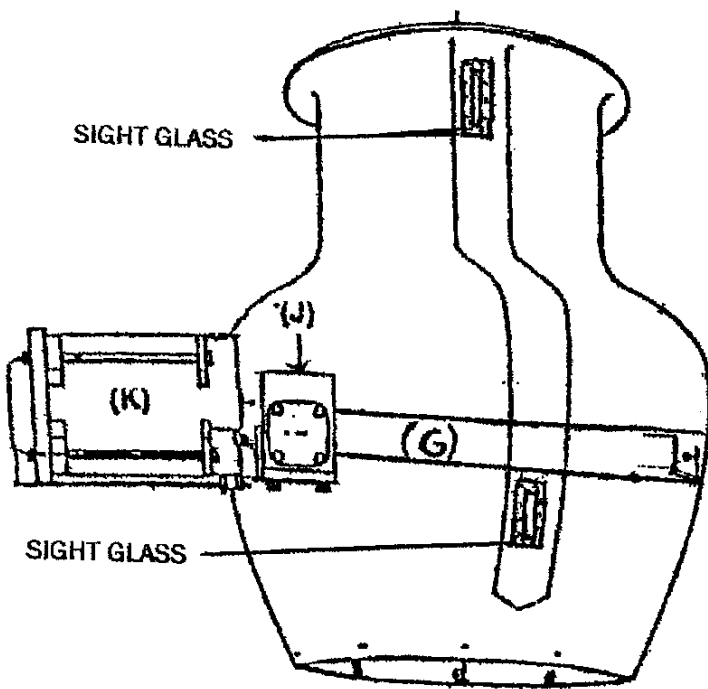

Model K-870-M

MOTORIZED ATTACHMENT

